

## Blast Chiller Freezers Crosswise Blast Chiller-Freezer Crosswise - 25kg 5GN 1/1 (R448A)

ITEM # \_\_\_\_\_

MODEL # \_\_\_\_\_

NAME # \_\_\_\_\_

SIS # \_\_\_\_\_

AIA # \_\_\_\_\_

**725446 (ECBCFB025UE)**

 Blast Chiller & Freezer  
 Crosswise 25kg, compatible  
 with 6x1/1GN Convection  
 Oven Crosswise - R448A

### Short Form Specification

#### Item No.

Blast chiller/freezer with digital temperature and time display. For 5 GN 1/1 or 600x400 mm trays (h = 65 mm). Load capacity: chilling 25 kg; freezing 15 kg. Automatic detection of food probe insertion. Automatic and Manual defrost. Blast chilling real remaining time estimation (A.R.T.E.). Turbo cooling function. Thawing function. HACCP and Service alarms with data logging. Connectivity ready. Operating air temperature: +10/-36°C. Single sensor food probe. Main components in 304 AISI stainless steel. Internal rounded corners and drain. Evaporator with antirust protection. Performances guaranteed at ambient temperature of +40°C. Cyclopentane insulation (HCFC, CFC and HFC free). R448a refrigerant gas (HCFC and CFC free). Built-in refrigeration unit.

### Main Features

- Blast Chilling cycle: 25 kg from 90°C up to 3°C.
- Chilling cycle with automatic preset cycles:
  - Soft Chilling, ideal for delicate food and small portions.
  - Hard Chilling, ideal for solid food and whole pieces.
- Freezing cycle with automatic preset cycles, ideal for all kind of food (raw, half or fully cooked).
- Turbo cooling: chiller works continuously at the desired temperature; ideal for continuous production.
- Thawing cycle, ideal for defrosting food in a controlled and safe environment.
- Possibility to modify the cavity temperature in turbo cooling and thawing cycles.
- Remaining time estimation for probe-driven cycles based on artificial intelligence techniques (ARTE) for an easier planning of the activities.
- Single sensor core probe as standard.
- On-board HACCP monitoring capable.
- Performance guaranteed at ambient temperatures of +40°C (Climatic class 5).
- Automatic and manual defrosting.
- Freezing cycle: 15 kg from 90°C up to -36°C.

### Construction

- No water connections required.
- Ventilator swinging hinged panel for access to the evaporator for cleaning.
- Waste water can be plumbed into drain, but can also be collected in an optional waste container.
- Built-in refrigeration unit.
- Main components in 304 AISI stainless steel.
- Evaporator with antirust protection.
- Automatic heated door frame.
- Door reversible on site.
- Door stopper to keep the door open in order to avoid the formation of bad smells (kit available to be mounted on site, depending on preferred door hinge).
- IP21 protection index.

### User Interface & Data Management

- Control unit provides two large displays to read out: time, core temperature, cycle countdown, alarms, service information.
- Connectivity ready for real time access to connected appliances from remote and HACCP monitoring (requires optional accessory).

APPROVAL: \_\_\_\_\_

## Sustainability



- Holding at +3 °C for chilling or -20 °C for freezing, automatically activated at the end of each cycle, to save energy and maintain the target temperature (manual activation is also possible).
- High density polyurethane insulation, 60 mm thickness, HCFC free.

## Included Accessories

- 1 of 1 single-sensor probe for blast chiller/freezers PNC 880213

## Optional Accessories

- 1 single-sensor probe for blast chiller/freezers PNC 880213
- Kit 4 feet for blast chiller/freezers crosswise 15-25 kg - h100mm PNC 881295
- Kit 4 wheels for blast chiller/freezers crosswise 15-25 kg - h100mm PNC 881296
- Pair of AISI 304 stainless steel grids, GN 1/1 PNC 921101
- Pair of AISI 304 stainless steel grids, GN 1/1 PNC 922017
- AISI 304 stainless steel grid, GN 1/1 PNC 922062
- AISI 304 stainless steel bakery/pastry grid 400x600mm PNC 922264
- IoT module for blast chiller/freezers crosswise PNC 922419
- POE switch PNC 922432

Front

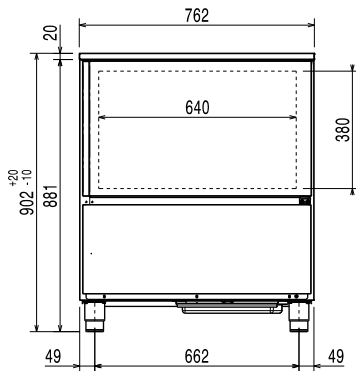

Side

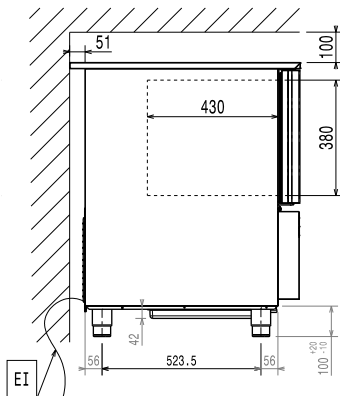

EI = Electrical inlet (power)

Top

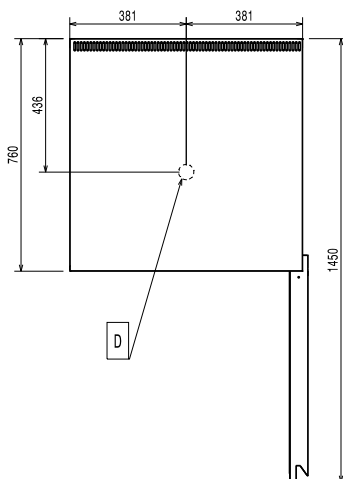

### Electric

#### Supply voltage:

725446 (ECBCFB025UE) 220-240 V/1 ph/50 Hz

#### Electrical power max.:

1.6 kW

#### Circuit breaker required

### Installation:

#### Clearance:

5 cm on sides and back.

Please see and follow detailed installation instructions provided with the unit

### Capacity:

**Number and type of grids:** 5 (GN 1/1; 600x400)

**Number and type of basins:** 4 (360x250x80h)

### Key Information:

**External dimensions, Width:** 762 mm

**External dimensions, Depth:** 760 mm

**External dimensions, Height:** 902 mm

**Net weight:** 85 kg

**Shipping weight:** 97 kg

**Shipping volume:** 0.72 m<sup>3</sup>

### Refrigeration Data

#### Refrigeration power at

evaporation temperature: -20 °C

### Product Information (EN17032 – Commission Regulation EU 2015/1095)

**Chilling Cycle Time (+65°C to +10°C):**

96 min

**Full load capacity (chilling):**

25 kg

**Freezing Cycle Time (+65°C to -18°C):**

248 min

**Full load capacity (freezing):**

15 kg

### ISO Certificates

#### ISO Standards:

ISO 9001; ISO 14001; ISO 45001; ISO 50001

### Sustainability

**Refrigerant type:**

R448A

**GWP Index:**

1387

**Refrigeration power:**

2004 W

**Refrigerant weight:**

850 g

**Energy consumption, cycle (chilling):**

0.0949 kWh/kg

**Energy consumption, cycle (freezing):**

0.3168 kWh/kg